

Waiver:

This data sheet is for guidance only and must not be used for proper working drawings. Please contact Stannah Lifts for particular details before proceeding. Owing to our policy of continual improvement we reserve the right to alter specifications and dimensions without prior notice.

SYSTEM 21



10 Person (800kg)

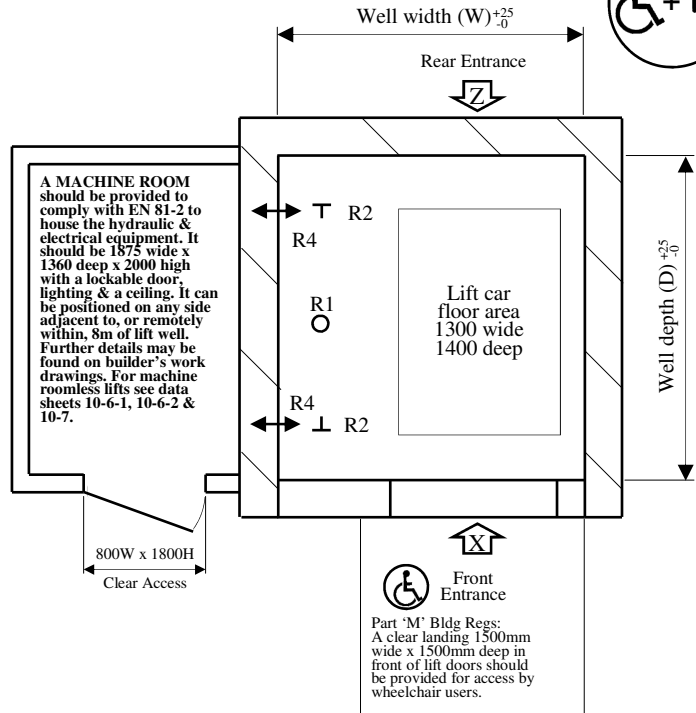
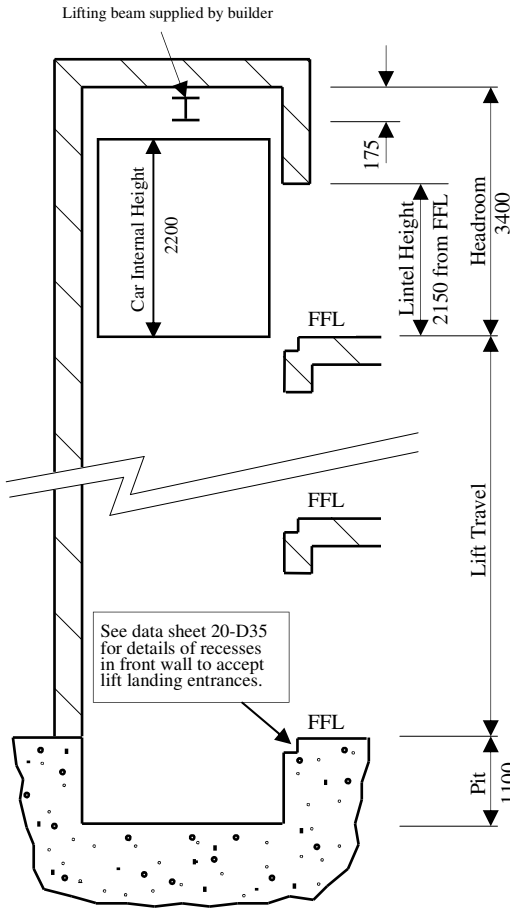

EQUIVALENT DEAD LOADS IMPOSED DUE TO LIFT OPERATION (kg)

		Wall Mounted Models	Type of Loading
Side Wall	Lift Pit Floor		
	R1	3675	Load due to car weight + load + hydraulic cylinder
	R2	3482	Load due to car buffering or safety gear operation
	R4	409	Push in/Pull out load

IMPORTANT

On Wall Mounted Models, Unistrut inserts ref P3270 to be built into lift pit and lift well walls by builder *before* installation. See specific Builder's Work Drawings for precise details.

WALL MOUNTED MODELS

MODEL REF	LIFT DOORS ARRANGEMENT	Plan Well Dimensions				Lift Car Clear Entrance			
		Front entrance X or Z		Front & rear entrance X & Z		W	H		
		Car Doors	Landing Doors	W	D	W	D	W	H
M10-2C 2C (800)		Auto 2 panel centre opening 2C	Auto 2 panel centre opening 2C	1900	1750	1900	1880	800	2000
M10-2C 2C (900)		Auto 2 panel centre opening 2C	Auto 2 panel centre opening 2C	2000	1750	2000	1880	900	2000

Note: Shaft sizes are for guidance purposes only and subject to change so it is crucial that you contact the supplier concerning your specific requirements.

Note: FX model (Structure Mounted) *not* available in this capacity. Wall Mounted only.