

Waiver:

This data sheet is for guidance only and must not be used for proper working drawings. Please contact Stannah Lifts for particular details before proceeding. Owing to our policy of continual improvement we reserve the right to alter specifications and dimensions without prior notice.

SYSTEM 21

Machine Room-Less

Totally Machine Room Free

MRLi

13 Person (1000kg) Square Shape



Option: MRLi-EC
Machine Room-less
- Entrance Controller

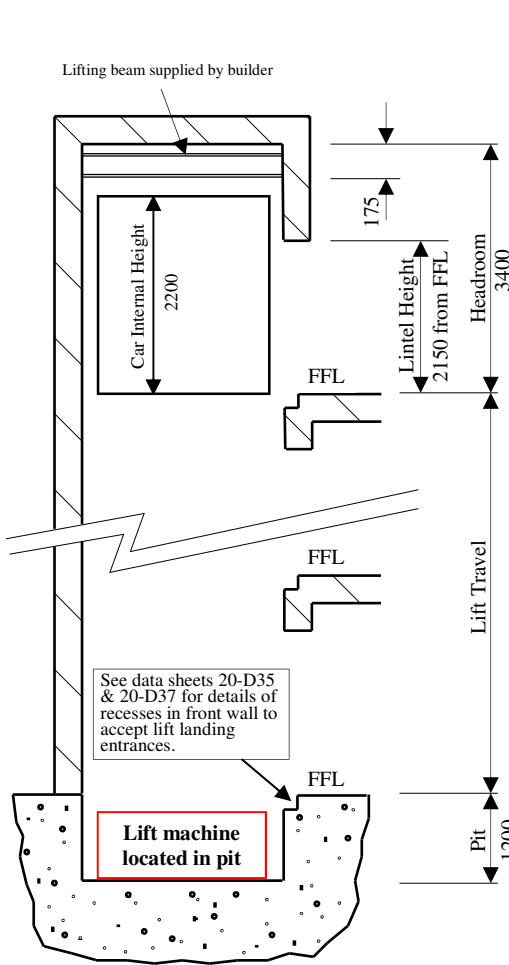

See data sheets 20-D35 & 20-D37 for details of recesses in front wall to accept lift landing entrances.

A 1 hr certified lift controller forms part of the lift entrance and can be positioned at any landing (the lowest landing is preferred). See data sheet 20-D37 for cut out details. Further details may be found on builders work drawings.

For alternative controller locations see data sheet 13-11-2

Travel: 12.3m max.
Speed: Up to 0.5 m/s

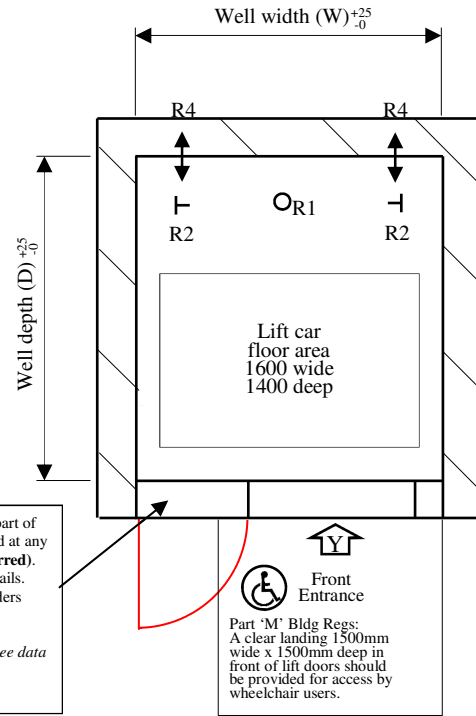

Front Entrance
Part 'M' Bldg Regs:
A clear landing 1500mm wide x 1500mm deep in front of lift doors should be provided for access by wheelchair users.

EQUIVALENT DEAD LOADS IMPOSED DUE TO LIFT OPERATION (kg)

		Wall Mounted Models	Type of Loading	
Side Wall	Lift Pit Floor	R1	4416	Load due to car weight + load + hydraulic cylinder
		R2	4200	Load due to car buffering or safety gear operation
		R4	529	Push in/Pull out load

IMPORTANT

On Wall Mounted Models, Unistrut inserts ref P3270 to be built into lift pit and lift well walls by builder *before* installation. See specific Builder's Work Drawings for precise details.

WALL MOUNTED MODELS

MODEL REF	LIFT DOORS ARRANGEMENT			Plan Well Dimensions				Lift Car Clear Entrance	
	Car Doors	Landing Doors	Diagram	Front entrance X or Z		Front & rear entrance X & Z		W	H
				W	D	W	D		
M13-2-2C 2C	Auto 2 panel centre opening 2C	Auto 2 panel centre opening 2C		2400	2050	Not Available	Not Available	1100	2000

Note: Shaft sizes are for guidance purposes only and subject to change so it is crucial that you contact Stannah concerning your specific requirements

Note: FX model (Structure Mounted) *not* available in this capacity. Wall Mounted only.

Machine Room-Less
MRLi
13-11-1
05/01/09